

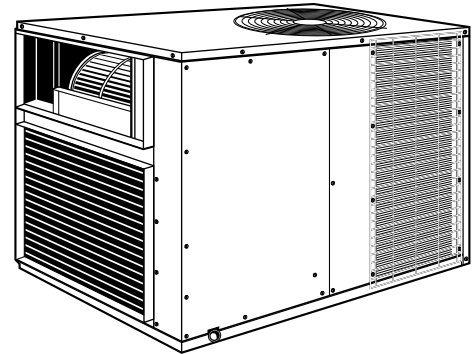

# Product Data

## Single Packaged Heat Pumps 14 SEER 2 – 3 1/2 Ton

4WHC4024A1000B  
4WHC4030A1000B  
4WHC4036A1000B  
4WHC4042A1000B



*Note: "Graphics in this document are for representation only. Actual model may differ in appearance."*



# Table of Contents

Single Packaged 14 SEER Heat Pump System .....	3
Optional Equipment Listing .....	4
Product Specifications .....	5
Heater Data .....	9
Field Hookup Diagram — 4WHC4 .....	9
Indoor Fan Performance .....	10
Outline Drawing .....	11
Mechanical Specifications .....	12



# Single Packaged 14 SEER Heat Pump System

## HORIZONTAL PACKAGED HEAT PUMPS

Trane 4WHC4 packaged heat pumps are designed for efficiency, reliability and easy installation.

Reliable electronic Demand Defrost, rugged compressor, filter drier and thermal expansion devices are the backbone of the Trane heat pump. We have also made installation easier and less costly by standardizing the cabinet and accessories. One standardized cabinet design for the 2-3-1/2 ton models.

**Single Packaged Electric Heat Pumps are easy and versatile to install.** These heat pump units have an over/under horizontal configuration which provides an efficient airflow delivery. This dedicated design eliminates the need for any unit conversion, saving field labor and installed cost.

**Better Installability** With standardized cabinet designs, all components were designed to be located in the same location, regardless of unit size.

**Better Serviceability** Our single packaged cooling/heating units offer efficiencies that are unmatched in the industry and provide you with a product far superior in performance than the competition.

With standardized cabinet designs, all components were designed to be located in the same location, regardless of unit size.

A simplified control panel that features colored and numbered wire is standard on all products. This aids in reducing troubleshooting time when wire tracing is required. And easy access to all major components can be accomplished by removing quick service access panels.

**Unmatched quality and reliability.** All major components on these products, including the compressor, have been designed and manufactured for maximum service. Every Climatuff™ compressor is designed and manufactured to exacting specifications. Each design is life tested in extreme environments to ensure reliable and long lasting operation in normal applications. Each compressor has internal motor protection for added reliability.

## Design Features

- Climatuff™ compressor, designed and manufactured to provide reliable, economical operation
- Internal pressure relief and internal overload protection
- High Efficiency multi-speed direct drive indoor fan motor. Variable speed direct drive blower motor on 4WHC4042 models.
- Thermal expansion valve refrigerant control.
- Demand defrost control system.
- Reliable, solenoid-operated reversing valve.
- Copper tube, aluminum plate fin coils.
- Polarized plug for easy field connection of low voltage to supplementary heater.
- Duct flanges.
- Outdoor coil guard.

## Accessories

- Supplemental Electric Heaters
- Thermostats
- Low ambient cooling to 0°F.



# Optional Equipment Listing

Optional Equipment for 4WHC4 Packaged Units (check mark indicates accessories included)

Anti-Short Cycle Timer <sup>(a)</sup> <sup>(b)</sup>	1BAYASCT001 [ ]
Extreme Conditions Mounting Kit - slab or rack mount	BAYECMT003A [ ]
Low Ambient Cooling Kit	BAYLOAM011A [ ]
5 Minute Delay Relay <sup>(b)</sup>	TAYASCT501A [ ]
3Heat/2Clg	TCONT402A[[ ]
2Heat/2Clg	TCONT602A [ ]
3Heat/2Clg	TCONT802A [ ]
3Heat/2Clg w/Humidity Display	TCONT803A [ ]

<sup>(a)</sup> Not for use with electronic thermostats.

<sup>(b)</sup> Activated on Power off



# Product Specifications

<b>MODEL</b>	4WHC4024A1000B	4WHC4030A1000B
RATED Volts/Ph/Hz	208-230/1/60	208-230/1/60
<b>Performance Cooling BTUH <sup>(a)</sup></b>	24800	30000
Indoor Airflow (CFM)	830	1050
Power Input (KW)	1.79	2.27
EER/SEER (BTU/Watt-Hr.) <sup>(b)</sup>	13.6 / 16.0	12.0 / 14.0
Sound Power Rating [dB(A)] <sup>(c)</sup>	74	74
<b>Performance (Heating)</b>		
(High Temp.) BTUH — C.O.P.	21200 — 3.79	25600 — 3.67
Power Input (KW)	1.73	2.16
(Low Temp.) BTUH — C.O.P.	11700 — 2.10	14700 — 2.15
Power Input (KW)	1.64	2.01
HSPF (BTU / Watt-Hr.)	8.2	8
<b>POWER CONN. V/Ph/Hz</b>	208-230/1/60	208-230/1/60
Min. Brch. Cir. Ampacity <sup>(d)</sup>	18.7	21.1
Fuse Size — Max. (amps)	25	30
Fuse Size — Recmd. (amps)	25	30
<b>COMPRESSOR</b>	SCROLL	SCROLL
No. Used — No. Speeds	1 — 1	1 — 1
Volts/Ph/Hz	208-230/1/60	208-230/1/60
R.L. Amps — L.R. Amps	10.9 / 63	12.8 / 68.0
<b>OUTDOOR COIL — TYPE</b>	PLATE FIN	PLATE FIN
Rows/F.P.I	2 / 22	2 / 22
Face Area (sq. ft.)	11.2	11.2
Tube Size (in.)	3/8	3/8
Refrigerant Control	TXV—NB	TXV—NB
<b>INDOOR COIL — TYPE</b>	PLATE FIN	PLATE FIN
Rows/F.P.I	4 / 12	4 / 12
Face Area (sq. ft.)	3.44	3.44
Tube Size (in.)	3/8	3/8
Refrigeration Control	TXV—NB	TXV—NB
Drain Conn. Size (in.)	3/4 FEMALE PVC	3/4 FEMALE PVC
Duct Connections	SEE OUTLINE DRAWING	SEE OUTLINE DRAWING
<b>OUTDOOR FAN — TYPE</b>	PROPELLER	PROPELLER
No. Used/Dia. (in)	1 / 20	1 / 20
Drive Type/No. Speeds	DIRECT / 1	DIRECT / 1
CFM @ 0.0 in. w.g. <sup>(e)</sup>	2500	2500
No. Motors — HP/RPM	1 / 1/5 / 850	1 / 1/5 / 850
Volts/Ph/Hz	208-230/1/60	208-230/1/60
F.L. Amps/L.R Amps	1.0 — 2.2	1.0 / 2.2
<b>INDOOR FAN — TYPE</b>	CENTRIFUGAL	CENTRIFUGAL
Dia. x Width (in.)	10 X 10	10 X 10
No. Used	1	1
Drive / Type / Speeds (No.)	DIRECT / CTM / 2	DIRECT / CTM / 2
CFM @ 0.0 in. w.g. <sup>(f)</sup>	SEE FAN PERF TABLE	SEE FAN PERF TABLE
Motor — HP/R.P.M.	1/ 0.5 / 1050	1/ 0.5 / 1050
Volts/Ph/Hz	208-230/1/60	208-230/1/60



## Product Specifications

F.L. Amps	4.1	4.1
<b>FILTER / FURNISHED</b>	NO	NO
Type Recommended	THROWAWAY	THROWAWAY
Recmd. Face Area (sq. ft) <sup>(g)</sup>	2.67	3.33
<b>REFRIGERANT</b>	R-410	R-410
Charge (lbs.)	7.5	7.8
Subcooling	6° F	10° F
<b>DIMENSIONS</b>	H X D X W	H X D X W
Crated (in.)	36 X 33-13/16 X 48	36 X 33-13/16 X 48
<b>WEIGHT</b>		
Shipping (lbs.) / Net (lbs.)	322 / 275	322 / 275

(a) Rated in accordance with AHRI Standard 210/240.

(b) Rated in accordance with D.O.E. test procedure.

(c) Sound Power values are not adjusted for AHRI 270-95 tonal corrections.

(d) Calculated in accordance with currently prevailing Nat'l Electrical Code.

(e) Standard Air — Dry Coil — Outdoor.

(f) Standard Air — Dry Coil — Indoor

(g) Filters must be installed in return air stream. Square footages listed are based on 300 f.p.m. face velocity. If permanent filters are used size per manufacturer's recommendation with a clean resistance of 0.05" W.C.

<b>MODEL</b>	4WHC4036A1000B	4WHC4042A1000B
RATED Volts/Ph/Hz	208-230/1/60	208-230/1/60
<b>Performance Cooling BTUH <sup>(a)</sup></b>	35800	39500
Indoor Airflow (CFM)	1070	1200
Power Input (KW)	2.92	3.27
EER/SEER (BTU/Watt-Hr.) <sup>(b)</sup>	12.0 / 14.0	12.0 / 14.0
Sound Power Rating [dB(A)] <sup>(c)</sup>	75	75
<b>Performance (Heating)</b>		
(High Temp.) BTUH — C.O.P.	32000 — 3.6	35000 — 4.37
Power Input (KW)	2.75	2.94
(Low Temp.) BTUH — C.O.P.	19500 — 2.30	21200 — 2.26
Power Input (KW)	2.48	2.75
HSPF (BTU / Watt-Hr.)	8	8
<b>POWER CONN. V/Ph/Hz</b>	208-230/1/60	208-230/1/60
Min. Brch. Cir. Ampacity <sup>(d)</sup>	26.2	30.5
Fuse Size — Max. (amps)	40	45
Fuse Size — Recmd. (amps)	40	45
<b>COMPRESSOR</b>	SCROLL	SCROLL
No. Used — No. Speeds	1 — 1	1 — 1
Volts/Ph/Hz	208-230/1/60	208-230/1/60
R.L. Amps — L.R. Amps	15.4 — 84	16.7 / 109
<b>OUTDOOR COIL — TYPE</b>	PLATE FIN	PLATE FIN
Rows/F.P.I	2 / 22	2 / 22
Face Area (sq. ft.)	11.2	12.3
Tube Size (in.)	3/8	3/8
Refrigerant Control	TXV—NB	TXV—NB
<b>INDOOR COIL — TYPE</b>	PLATE FIN	PLATE FIN
Rows/F.P.I	4 / 12	5 / 15
Face Area (sq. ft.)	3.44	3.44
Tube Size (in.)	3/8	3/8
Refrigeration Control	TXV—NB	TXV—NB
Drain Conn. Size (in.)	3/4 FEMALE PVC	3/4 FEMALE PVC
Duct Connections	SEE OUTLINE DRAWING	SEE OUTLINE DRAWING
<b>OUTDOOR FAN — TYPE</b>	PROPELLER	PROPELLER
No. Used/Dia. (in)	1 / 20	1 / 20
Type Drive/No. Speeds	ECM / 1	ECM / 1
CFM @ 0.0 in. w.g. <sup>(e)</sup>	2500	2600
No. Motors — HP/RPM	1 / 1/3 / 850	1 / 1/3 / 850
Volts/Ph/Hz	208-230/1/60	208-230/1/60
F.L. Amps/L.R Amps	2.8	2.8
<b>INDOOR FAN — TYPE</b>	CENTRIFUGAL	CENTRIFUGAL
Dia. x Width (in.)	10 X 10	10 X 10
No. Used	1	1
Drive / Type / Speeds (No.)	DIRECT / CTM / 2	DIRECT / VSPD / 3
CFM @ 0.0 in. w.g. <sup>(f)</sup>	SEE FAN PERF TABLE	SEE FAN PERF TABLE
Motor — HP/R.P.M.	1/ 0.5 / 1050	1/ 0.75 / VARIABLE
Volts/Ph/Hz	208-230/1/60	208-230/1/60
F.L. Amps	4.1	6.8
<b>FILTER / FURNISHED</b>	NO	NO



## Product Specifications

Type Recommended	THROWAWAY	THROWAWAY
Recmd. Face Area (sq. ft) <sup>(g)</sup>	4.00	4.67
<b>REFRIGERANT</b>	R-410	R-410
Charge (lbs.)	7.2	8.7
Subcooling	8° F	10° F
<b>DIMENSIONS</b>	H X D X W	H X D X W
Crated (in.)	36 X 33-3/4 X 48	36 X 33-13/16 X 48
<b>WEIGHT</b>		
Shipping (lbs.) / Net (lbs.)	322 / 275	353 / 306

- (a) Rated in accordance with AHRI Standard 210/240.
- (b) Rated in accordance with D.O.E. test procedure.
- (c) Sound Power values are not adjusted for AHRI 270-95 tonal corrections.
- (d) Calculated in accordance with currently prevailing Nat'l Electrical Code.
- (e) Standard Air — Dry Coil — Outdoor.
- (f) Standard Air — Dry Coil — Indoor
- (g) Filters must be installed in return air stream. Square footages listed are based on 300 f.p.m. face velocity. If permanent filters are used size per manufacturer's recommendation with a clean resistance of 0.05" W.C.



# Heater Data

Unit Model	Electric Heater Model	Rated Voltage	Phase	Heater Capacity		No. of Stages	KW/Stage		MCA <sup>(a)</sup> <sub>(b)</sub>	Max Fuse or HACR CKT BKR Size <sup>(c)</sup>	Canada Only Max. CKT BKR Size <sup>(d)</sup>
				KW	BTUH		1	2			
4WHC4024A1000*	BAYHTRC106A BAYHTRC111A	208/ 240	1	4.33/5.76 7.93/10.56	14800/19600 27000/36000	1	4.33/5.76 7.93/10.56	-	26/30 48/55	30/30 50/60	30/30 50/60
4WHC4030A1000*	BAYHTRC106A BAYHTRC111A BAYHTRC117A <sup>(e)</sup>	208/ 240	1	4.33/5.76 7.93/10.56 12.98/17.28	14800/19600 27000/36000 44300/59000	1	4.33/5.76 7.93/10.56 12.98/17.28	-	26/30 48/55 78/90	30/30 50/60 80/90	30/30 50/60 100/100
4WHC4036A1000*	BAYHTRC106A BAYHTRC109A BAYHTRC111A BAYHTRC117A <sup>(e)</sup>	208/ 240	1	4.33/5.76 6.12/8.16 7.93/10.56 12.98/17.28	14800/19600 20900/27800 27000/36000 44300/59000	1	4.33/5.76 6.12/8.16 7.93/10.56 12.98/17.28	-	26/30 37/43 48/55 78/90	30/30 40/45 50/60 80/90	30/30 40/50 50/60 100/100
4WHC4042A1000*	BAYHTRC106A BAYHTRC109A BAYHTRC111A BAYHTRC117A <sup>(e)</sup>	208/ 240	1	4.33/5.76 6.12/8.16 7.93/10.56 12.98/17.28	14800/19600 20900/27800 27000/36000 44300/59000	1	4.33/5.76 6.12/8.16 7.93/10.56 12.98/17.28	-	26/30 37/43 48/55 78/90	30/30 40/45 50/60 80/90	30/30 40/50 50/60 100/100

**Notes:**

1. All power supplies and circuits must be wired and protected in accordance with local electrical codes.

(a) The MCA values listed are for electric heater only.

(b) Field wire must be rated at least 75°C

(c) The HACR circuit breaker is for U.S.A. installations only.

(d) For Canada installation reference only.

(e) Heater uses fuses.

## Field Hookup Diagram — 4WHC4

Figure 1. Field Hookup Diagram (With Supplementary Heaters)

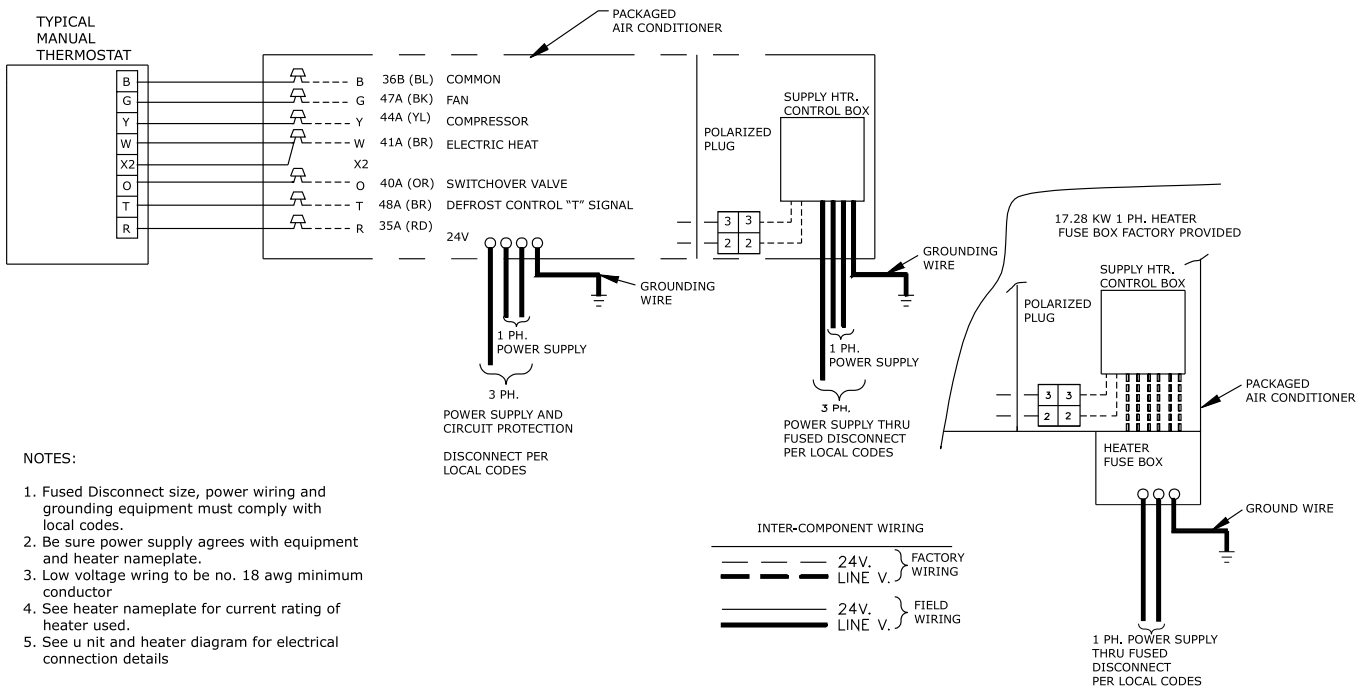



# Indoor Fan Performance

4WHC4024A1		EXTERNAL STATIC PRESSURE (IN. WG)			
MOTOR SPEED		0.2	0.3	0.4	0.5
LOW <sup>(a)</sup>	WATTS	145	152	160	168
	CFM	880	844	800	757
HIGH	WATTS	192	199	212	226
	CFM	985	943	906	867
WET COIL, NO FILTERS					

<sup>(a)</sup> FACTORY SETTING

4WHC4030A1		EXTERNAL STATIC PRESSURE (IN. WG)			
MOTOR SPEED		0.2	0.3	0.4	0.5
LOW <sup>(a)</sup>	WATTS	220	225	245	—
	CFM	1060	1005	965	—
HIGH	WATTS	260	270	280	285
	CFM	1135	1090	1055	1015
WET COIL, NO FILTERS					

<sup>(a)</sup> FACTORY SETTING

4WHC4036A1		EXTERNAL STATIC PRESSURE (IN. WG)			
MOTOR SPEED		0.2	0.3	0.4	0.5
LOW <sup>(a)</sup>	WATTS	325	330	340	350
	CFM	1205	1160	1115	1075
HIGH	WATTS	410	415	410	395
	CFM	1325	1275	1215	1150
WET COIL, NO FILTERS					

<sup>(a)</sup> FACTORY SETTING

4WHC4042A1		EXTERNAL STATIC PRESSURE (IN. WG)														
AIRFLOW SETTING	DIPSWITCH SETTINGS				.20		.30		.40		.50		.60		.70	
	1	2	3	4	CFM	WATTS	CFM	WATTS	CFM	WATTS	CFM	WATTS	CFM	WATTS	CFM	WATTS
350 CFM/TON	Off	Off	Off	On	1235	356	1238	391	1246	433	1245	466	1247	500	1250	538
400 <sup>(a)</sup> CFM/TON	Off	Off	Off	Off	1408	505	1410	529	1415	574	1415	609	1408	637	1380	633
450 CFM/TON	Off	Off	Off	Off	1572	613	1576	651	1569	683	1545	700	1540	720	1531	738
WET COIL, NO FILTERS																

<sup>(a)</sup> FACTORY SETTING

# Outline Drawing

Figure 2. Dimensional Drawing

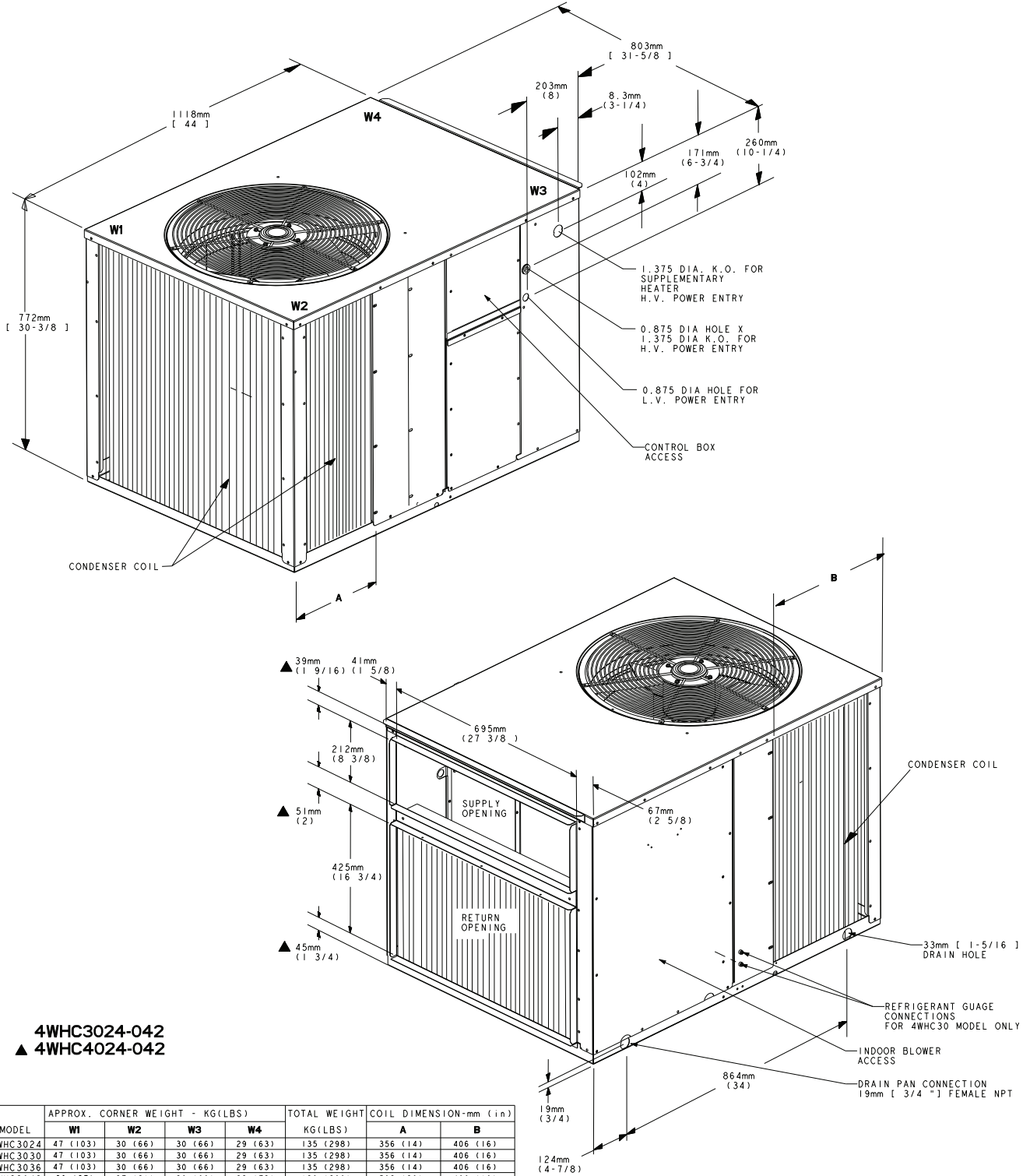

4WHC3024-042  
▲ 4WHC4024-042

MODEL	APPROX. CORNER WEIGHT - KG(LBS)				TOTAL WEIGHT KG(LBS)	COIL DIMENSION-mm (in)	
	W1	W2	W3	W4		A	B
4WHC3024	47 (103)	30 (66)	30 (66)	29 (63)	135 (298)	356 (14)	406 (16)
4WHC3030	47 (103)	30 (66)	30 (66)	29 (63)	135 (298)	356 (14)	406 (16)
4WHC3036	47 (103)	30 (66)	30 (66)	29 (63)	135 (298)	356 (14)	406 (16)
4WHC3042	39 (87)	37 (81)	30 (66)	33 (72)	139 (306)	508 (20)	406 (16)
4WHC4024	35 (78)	33 (73)	27 (59)	30 (65)	125 (275)	356 (14)	406 (16)
▲ 4WHC4030	35 (78)	33 (73)	27 (59)	30 (65)	125 (275)	356 (14)	406 (16)
▲ 4WHC4036	35 (78)	33 (73)	27 (59)	30 (65)	125 (275)	356 (14)	406 (16)
▲ 4WHC4042	39 (87)	37 (81)	30 (66)	33 (72)	139 (306)	508 (20)	406 (16)



# Mechanical Specifications

## General

All units are factory assembled, piped, internally wired and fully charged with R-410A. Units are certified to UL Standard 1995. All units are factory run-tested to check cooling and heating operation, defrost operation, fan and blower rotation and control sequence. Units shall be designed to operate at ambient temperatures as high as 115°F. Cooling and heating performances are rated in accordance with AHRI standards. Units are designed for either rooftop or ground level installation. All units shall be dedicated horizontal airflow and are not convertible.

## Unit Casing

All components are mounted in a weather-resistant steel cabinet with a baked-on enamel finish. Access panels are provided for unit controls, indoor coil and supply air fan. Top covers shall be removable for access or installation of electric heaters and outdoor fan and compressor. Indoor air section is completely insulated with fireproof, permanent, odorless glass fiber material. Knockouts are provided for utility and control connections. Drain connections are provided to accommodate indoor coil water runoff.

## Compressor

Hermetically sealed, high efficiency Climatuff™ compressor designed for heat pump duty. Internal over current and over temperature protection, low pressure protection.

## Refrigerant Circuit

All units have thermostatic expansion valve refrigerant control for heating and cooling operation. Service pressure tap ports, check valves, solenoid-operated reversing valve, and refrigerant line filter driers are standard.

## Indoor and Outdoor Coil

Indoor and outdoor coils are constructed of aluminum plate fins mechanically bonded to 0.375 inch seamless copper tubing.

## Outdoor Fan

One, direct-drive, statically and dynamically balanced propeller fan is used in a top discharge configuration. Permanently lubricated weatherproof motors have built-in thermal overload protection.

## Indoor Fan

Forward-curved, centrifugal-type fan with multispeed, Direct-drive Constant Torque Motor on 2 – 3 ton models and a Direct-drive Variable Speed Motor on 3 1/2 ton models. Permanently lubricated with built-in overload protection.

## Demand Defrost Control

Microcomputer logic is used to sense the need for defrost and permits defrost cycles only when coil icing conditions begin to cause serious heat pump capacity reductions.

## Accessories

Supplemental Electric Heater-Heater module shall mount in unit discharge air passage. Each heater assembly includes automatically resetting heat limit switches for thermal protection. A polarized plug provides connection to unit low voltage control wiring.

## Indoor Thermostat

Two-stage heating, one-stage cooling thermostat is available in either manual or automatic changeover. Thermostat provides automatic or continuous fan operation and includes outdoor thermistor, emergency heat switch with indicator light, and auxiliary heat indicator light.

## Low Ambient Control Kit

Provides low ambient cooling operation to 0°F









Ingersoll Rand (NYSE: IR) advances the quality of life by creating comfortable, sustainable and efficient environments. Our people and our family of brands — including Club Car®, Ingersoll Rand®, Thermo King® and Trane® — work together to enhance the quality and comfort of air in homes and buildings; transport and protect food and perishables; and increase industrial productivity and efficiency. We are a global business committed to a world of sustainable progress and enduring results.



[ingersollrand.com](http://ingersollrand.com)



Ingersoll Rand has a policy of continuous product and product data improvements and reserves the right to change design and specifications without notice.  
We are committed to using environmentally conscious print practices.